 <p>① VISSER LE TIROIR SUR L'INSERT COURT</p>	 <p>② ENGAGER L'ENSEMBLE TIROIR DANS LE TROU Ø13.5</p>	 <p>③ APPUYER SUR LE LEVIER</p>  <p>④ ENGAGER LE NEZ DE LA PRESSE SUR LE BOUTON MOLETE DU TIROIR</p>
 <p>⑤ POUSSER LA PRESSE VERS LE RAIL</p>  <p>⑥ ACTIONNER LE BRAS MOBILE</p>	 <p>⑦ POMPER DOUCEMENT JUSQU'AU DECLIC SONORE DU DECLENCHEMENT AUTOMATIQUE.</p> <p>REPERE VISUEL DE DEPLACEMENT DU PISTON</p> <p>"CLICK"</p>	 <p>⑧ APPUYER SUR LE LEVIER</p>  <p>⑨ RETIRER LA PRESSE</p>
 <p>⑩ DEVISSER LE TIROIR</p>	 <p>⑪ -METTRE EN PLACE LA COSSE DE RACCORDEMENT. -PLACER LA RONDELLE ANTIFRICTION ENTRE LA COSSE ET L'ECROU. -SERRER L'ECROU AU COUPLE DE 40 N.m -POUR LA POSE DU 2ème INSERT COURT REPETER LES OPERATIONS ① A ⑩.</p>	

DEMONTAGE DES INSERTS COURTS

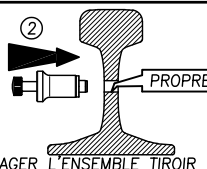
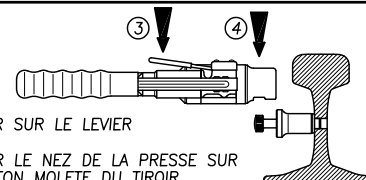
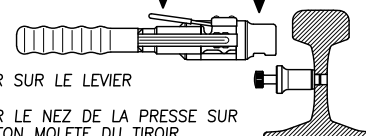
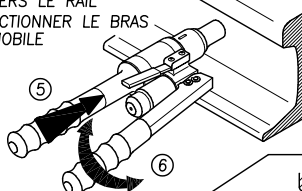
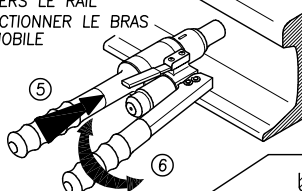
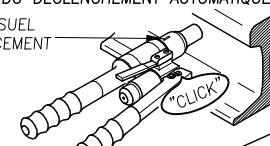
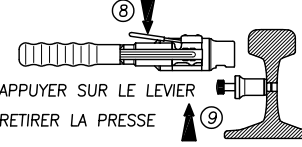
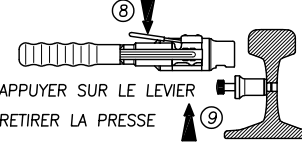
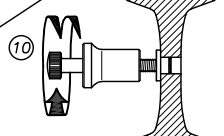
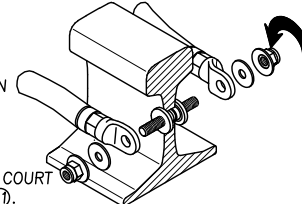